

## Indexing Plungers

Steel / Stainless Steel with rest position

### SPECIFICATION

#### Types

- Type **A**: with Plastic-Knob, without lock nut
- Type **AK**: with Plastic-Knob, with lock nut
- Type **AN**: with Stainless Steel-Knob, without lock nut
- Type **AKN**: with Stainless Steel-Knob, with lock nut

#### Version in Steel

- blackened
- Pin hardened

#### Version in Stainless Steel AISI 303 NI

Pin chemically nickel plated

Knob Type A / AK

- Plastic (Polyamide PA)
- black, matt
- not removable

Knob Type AN / AKN

- Stainless Steel AISI 303
- not removable

### INFORMATION

Indexing plungers GN 617.1 with rest position are used for such applications where the plunger has to stay in its retracted position. To achieve this, the knob is rotated by 90° degrees after being retracted. A notch keeps the plunger in this position.

- Range of indexing plungers (see page 738)

### TECHNICAL INFORMATION

- ISO-Fundamental Tolerances (see page A21)
- Stainless Steel characteristics (see page A26)
- Plastic characteristics (see page A2)

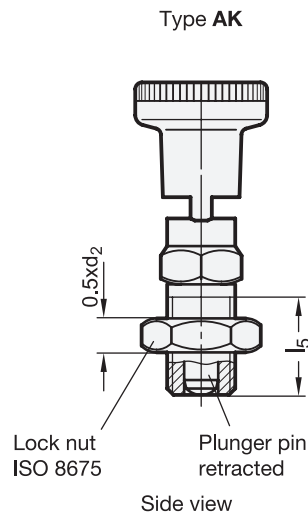
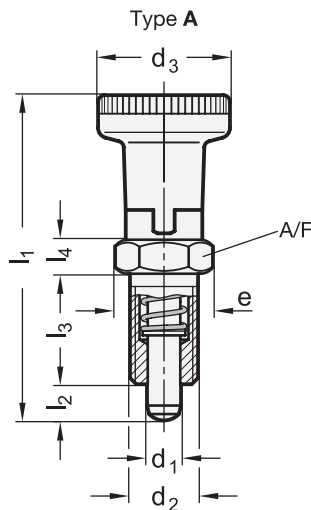

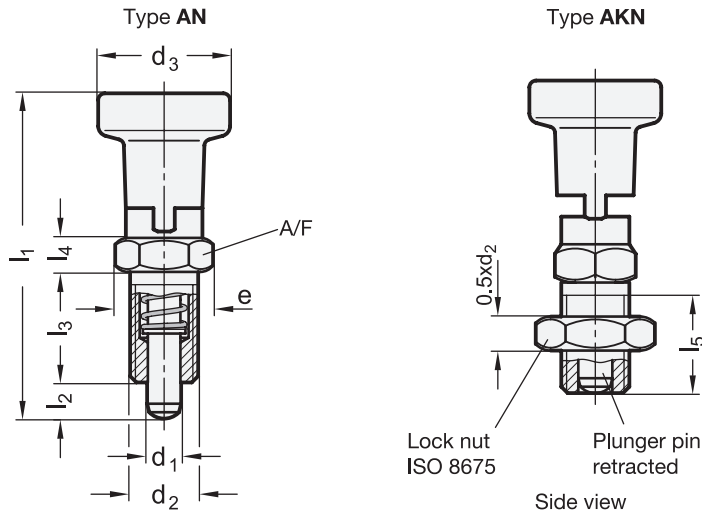

### GN 617.1 (Steel with Plastic knob)

Description	d1 Pin -0.02/-0.05 Bore H7	d2	d3	e	l1 ≈	l2	l3	l4	l5 min.	A/F	Spring load in N ≈ initial	Spring load in N ≈ end	⚖
GN 617.1-5-A	5	M 10 x 1	21	13.8	51	5	17	5	15	12	7	17	22
GN 617.1-6-A	6	M 12 x 1.5	25	16.2	61	6	20	6	17	14	9	24	35
GN 617.1-8-A	8	M 16 x 1.5	31	21.9	75.5	7	26	8	23	19	11	30	78
GN 617.1-10-A	10	M 20 x 1.5	31	25.4	91	10	33	10	30	22	19	45	100
GN 617.1-5-AK	5	M 10 x 1	21	13.8	51	5	17	5	15	12	7	17	27
GN 617.1-6-AK	6	M 12 x 1.5	25	16.2	61	6	20	6	17	14	9	24	43
GN 617.1-8-AK	8	M 16 x 1.5	31	21.9	75.5	7	26	8	23	19	11	30	96
GN 617.1-10-AK	10	M 20 x 1.5	31	25.4	91	10	33	10	30	22	19	45	163

### GN 617.1-NI (Stainless Steel with Plastic knob)

**STAINLESS STEEL**

Description	d1 Pin -0.02/-0.05 Bore H7	d2	d3	e	l1 ≈	l2	l3	l4	l5 min.	A/F	Spring load in N ≈ initial	Spring load in N ≈ end	⚖
GN 617.1-5-A-NI	5	M 10 x 1	21	13.8	51	5	17	5	15	12	6	15	22
GN 617.1-6-A-NI	6	M 12 x 1.5	25	16.2	61	6	20	6	17	14	8	21	36
GN 617.1-8-A-NI	8	M 16 x 1.5	31	21.9	75.5	7	26	8	23	19	9	26	79
GN 617.1-10-A-NI	10	M 20 x 1.5	31	25.4	91	10	33	10	30	22	17	40	135
GN 617.1-5-AK-NI	5	M 10 x 1	21	13.8	51	5	17	5	15	12	6	15	27
GN 617.1-6-AK-NI	6	M 12 x 1.5	25	16.2	61	6	20	6	17	14	8	21	43
GN 617.1-8-AK-NI	8	M 16 x 1.5	31	21.9	75.5	7	26	8	23	19	9	26	96
GN 617.1-10-AK-NI	10	M 20 x 1.5	31	25.4	91	10	33	10	30	22	17	40	136

### GN 617.1-NI (Stainless Steel knob)

**STAINLESS STEEL**

Description	d1 Pin -0.02/-0.05 Bore H7	d2	d3	e	l1 ≈	l2	l3	l4	l5 min.	A/F	Spring load in N ≈ initial	Spring load in N ≈ end	⚖
GN 617.1-5-AN-NI	5	M 10 x 1	21	13.8	51	5	17	5	15	12	6	15	47
GN 617.1-6-AN-NI	6	M 12 x 1.5	25	16.2	61	6	20	6	17	14	8	21	74
GN 617.1-8-AN-NI	8	M 16 x 1.5	31	21.9	75.5	7	26	8	23	19	9	26	150
GN 617.1-10-AN-NI	10	M 20 x 1.5	31	25.4	91	10	33	10	30	22	17	40	200
GN 617.1-5-AKN-NI	5	M 10 x 1	21	13.8	51	5	17	5	15	12	6	15	52
GN 617.1-6-AKN-NI	6	M 12 x 1.5	25	16.2	61	6	20	6	17	14	8	21	82
GN 617.1-8-AKN-NI	8	M 16 x 1.5	31	21.9	75.5	7	26	8	23	19	9	26	168
GN 617.1-10-AKN-NI	10	M 20 x 1.5	31	25.4	91	10	33	10	30	22	17	40	240

